



TE0711 TRM

Revision v.35

Exported on 2019-02-21

Online version of this document:

<https://wiki.trenz-electronic.de/display/PD/TE0711+TRM>

1 Table of Contents

1	Table of Contents.....	2
2	Table of Figures.....	4
3	Table of Tables.....	5
4	Overview.....	6
4.1	Key Features.....	6
4.2	Block Diagram.....	7
4.3	Main Components.....	8
4.4	Initial Delivery State.....	9
5	Signals, Interfaces and Pins.....	10
5.1	Board to Board (B2B) I/Os.....	10
5.2	JTAG Interface.....	10
5.3	System Controller I/O Pins.....	11
5.4	On-board LEDs.....	11
5.5	Clocking.....	12
6	On-board Peripherals.....	13
6.1	32 MByte Quad SPI Flash Memory.....	13
6.2	System Controller CPLD.....	13
6.3	Dual channel USB to UART/FIFO.....	13
7	Power and Power-On Sequence.....	14
7.1	Power Supply.....	14
7.2	Power-On Sequence.....	14
7.3	Power Rails.....	15
7.4	Bank Voltages.....	15
8	Board to Board Connectors.....	16
8.1	Connector Mating height.....	16
8.2	Connector Speed Ratings.....	17
8.3	Current Rating.....	17
8.4	Connector Mechanical Ratings.....	17
9	Variants Currently In Production.....	18
10	Technical Specifications.....	19
10.1	Absolute Maximum Ratings.....	19
10.2	Recommended Operating Conditions.....	19
10.3	Operating Temperature Ranges.....	20
10.4	Physical Dimensions.....	20
10.5	Weight.....	21

11	Revision History	22
11.1	Hardware Revision History	22
11.2	Document Change History	22
12	Disclaimer.....	23
12.1	Data privacy	23
12.2	Document Warranty.....	23
12.3	Limitation of Liability.....	23
12.4	Copyright Notice	23
12.5	Technology Licenses.....	23
12.6	Environmental Protection	23
12.7	REACH, RoHS and WEEE	23

2 Table of Figures

3 Table of Tables

Table 1: Connectors.	16
Table 2: Speed rating.	17

4 Overview

Refer to <https://wiki.trenz-electronic.de/display/PD/TE0711+TRM> for online version of this manual and the rest of available documentation. Trenz Electronic TE0711 is an industrial-grade FPGA module integrating a Xilinx Artix-7 FPGA, 32 MByte Quad SPI Flash memory for configuration and operation and powerful switching-mode power supplies for all on-board voltages. Numerous configurable I/O's are provided via rugged high-speed strips. All this on a tiny footprint, smaller than a credit card size at very competitive price. All Trenz Electronic SoM's in 4 x 5 cm form factor are mechanically compatible.

4.1 Key Features

- Industrial-grade Xilinx Artix-7 (15T to 100T) FPGA, supported by the free [Xilinx Vivado WebPACK¹](#) tool
- Rugged for shock and high vibration
- FTDI FT2232H USB 2.0 high-speed to UART/FIFO
- 32 MByte QSPI Flash memory (with XiP support)
- 100 MHz MEMS oscillator
- Plug-on module with 2 × 100-pin and 1 × 60-pin high-speed hermaphroditic strips
- 178 FPGA I/Os (84 differential pairs) are available on board-to-board connectors
- On-board high-efficiency DC-DC converters
 - 4.0 A x 1.0 V power rail
 - 1.0 A x 1.8 V power rail
 - 1.0 A x 1.5 V power rail
- System management and power sequencing
- eFUSE bit-stream encryption
- AES bit-stream encryption
- User LED
- Evenly-spread supply pins for good signal integrity

Assembly options for cost or performance optimization available upon request.

¹ http://www.xilinx.com/products/design_tools/vivado/vivado-webpack.htm

4.2 Block Diagram

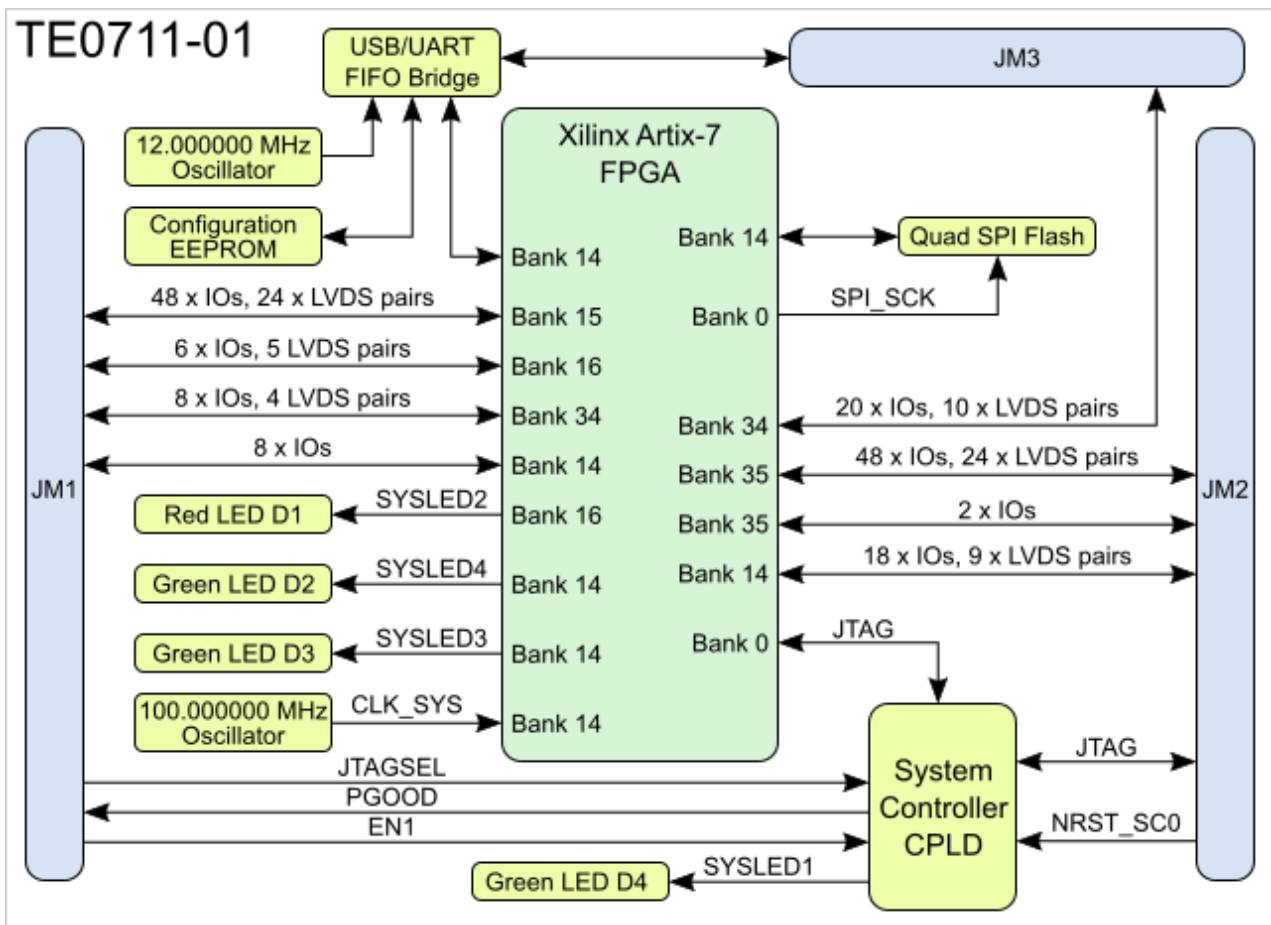

Figure 1: TE0711-01 block diagram.

4.3 Main Components

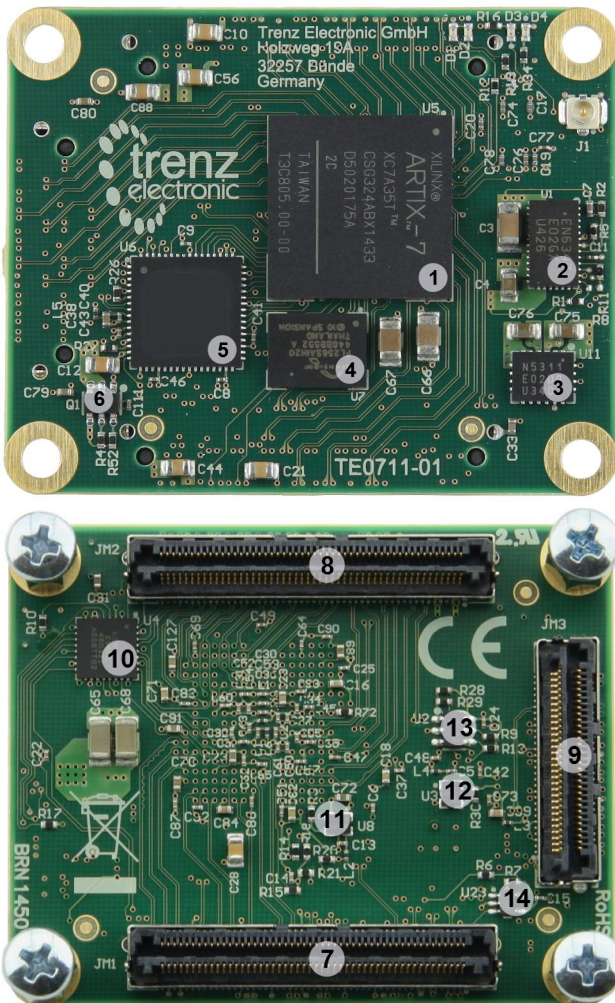

Figure 2: TE0711-01 PCB.

1. Xilinx Artix-7 FPGA, U5
2. 4A PowerSoC DC-DC converter for 1.0V (Altera EN6347QI), U1
3. 1A PowerSoC DC-DC converter for 1.8V (Altera EN5311QI), U11
4. 32 MByte Quad SPI Flash memory 32 MByte Quad SPI Flash memory (Cypress S25FL256S), U7
5. Dual USB to UART/FIFO bridge (FTDI FT2232H), U6
6. Load switch for 3.3V voltage level (Texas Instruments TPS27082L), Q1
7. B2B connector Samtec Razor Beam™ LSHM-150, JM1
8. B2B connector Samtec Razor Beam™ LSHM-150, JM2
9. B2B connector Samtec Razor Beam™ LSHM-130, JM3
10. System Controller CPLD (Lattice Semiconductor LCMXO2-256HC), U4
11. 100.000000 MHz reference clock connected to the FPGA bank 14 (SiTime SiT8008), U8
12. 12.000000 MHz reference clock connected to the USB to UART/FIFO bridge (SiTime SiT8008), U3
13. Configuration data serial EEPROM for USB to UART/FIFO bridge (Microchip 93AA56), U2
14. Voltage detector for "Power OK" signalling (Texas Instruments TPS3805H3), U23

4.4 Initial Delivery State

Storage Component	Content	Notes
SPI Flash OTP Area	Empty, not programmed	Except serial number programmed by flash vendor.
SPI Flash Quad Enable bit	Programmed	-
SPI Flash main array	Demo design	-
EFUSE USER	Not programmed	-
EFUSE Security	Not programmed	-

Table 1: TE0711-01 initial delivery state.

5 Signals, Interfaces and Pins

5.1 Board to Board (B2B) I/Os

I/O signals connected to the FPGA's I/O banks and B2B connector:

Bank	Type	B2B Connector	I/O Signal Count	Voltage	Notes
14	HR	JM1 JM2	8 I/O pins 18 I/O pins, (9 LVDS pairs)	3.3V	HR banks support voltages from 1.2V to 3.3V. See Xilinx Artix-7 datasheet (DS181²) for voltage ranges.
15	HR	JM1	48 I/O pins 24 LVDS pairs	User	As above.
16	HR	JM1	6 I/O pins 3 LVDS pairs	1.8V	As above.
34	HR	JM1 JM3	48 I/O pins 24 LVDS pairs	User	As above.
35	HR	JM2	50 I/O pins 24 LVDS pairs	User	As above.

Table 2: Voltage ranges and pin-outs of available logic banks of the FPGA.

Refer to [Master Pin-out Table³](#) as primary reference for the pin mapping information.

5.2 JTAG Interface

JTAG access to the Xilinx Artix-7 and to the System Controller CPLD is provided through B2B connector JM2.

JTAG Signal	B2B Connector
TCK	JM2-99

² http://www.xilinx.com/support/documentation/data_sheets/ds181_Artix_7_Data_Sheet.pdf

³ https://shop.trenz-electronic.de/de/Download/?path=Trenz_Electronic/Pinout

JTAG Signal	B2B Connector
TDI	JM2-95
TDO	JM2-97
TMS	JM2-93

Table 3: Pin mapping of JTAG Interface on B2B connector

⚠ JTAGSEL pin on B2B connector JM1 is used to control which physical device is accessible via JTAG interface. If this pin is set to low or left open, JTAG interface is enabled for Xilinx Artix-7 FPGA, if set to high, JTAG interface for System Controller CPLD will be enabled. The use of Xilinx legacy development tools (ISE, iMPACT) is not recommended. iMPACT does not recognize any Xilinx Artix-7 below A100T model.

5.3 System Controller I/O Pins

Special purpose pins are connected to smaller System Controller CPLD and have following default configuration:

Pin Name	Mode	Function	Default Configuration	B2B Connector
STAT_SC2	Output	Power Good	Active high when all on-module power supplies are working properly.	JM1-30
NRST_SC0	Input	Reset	Active low reset signal, drive low to keep the system in reset (FPGA pin PROG_B will be driven by CPLD).	JM2-18
JTAGSEL	Input	JTAG Select	Low for normal operation, high (3.3V) to program the System Controller CPLD.	JM1-89
EN_SC3	Input	Enable FPGA Core Voltage supply	High (3.3V) or open for normal operation, low to stop power-on sequencing.	JM1-28

Table 4: Pin description of System Controller CPLD.

5.4 On-board LEDs

The TE0711 SoM has total of 4 on-board LED's. LED's D1, D2 and D3 are connected to the Xilinx Artix-7 FPGA and can be freely used by user design. LED D4 is the System Controller CPLD status LED.

LED	Color	Connected to	Description and Notes
D1	Red	SYSLED2	User LED, active HIGH, connected to FPGA Pin A8
D2	Green	SYSLED4	User LED, active HIGH, connected to FPGA Pin R17
D3	Green	SYSLED3	User LED, active LOW, connected to FPGA Pin L15
D4	Green	SYSLED1	System Controller status LED, connected to CPLD

Table 5: Description of on-board LED's.

5.5 Clocking

The TE0711-01 is equipped with MEMS oscillator (SiT8008AI-73-XXS-100.000000E, U8) to provide 100 MHz clock signal for Xilinx Artix-7 FPGA pin P17.

6 On-board Peripherals

6.1 32 MByte Quad SPI Flash Memory

On-board SPI flash memory S25FL256S (U7) is used to store initial FPGA configuration. Besides FPGA configuration, remaining free flash memory can be used for user application storage. All four SPI data lines are connected to the FPGA allowing x1, x2 or x4 data bus widths. Maximum data rate depends on the bus width and clock frequency used.

⚠ SPI Flash QE (Quad Enable) bit must be set to high or FPGA is unable to load its configuration from flash. By default this bit is set to high at the manufacturing plant.

6.2 System Controller CPLD

The system controller is used to coordinate the configuration of the FPGA. The FPGA is held in reset (by driving the PROG_B signal) until the power supplies have sequenced. Low level at NRST_SC0 pin also resets the FPGA. This signal can be driven from the user's PCB via the B2B connector pin JM2-18. Input EN_SC3 is also gated to FPGA Reset and should be open or pulled up for normal operation. EN_SC3 low turns off on board DC-DC converters and stops power-on sequencing.

It is possible for the user to create their own system controller design using the [Lattice Diamond software](#)⁴. Once created the design can be programmed into the device using the JTAG pins. The signal JTAGSEL should be set to 3.3V to enable programming mode. For normal operation it should be set to 0V.

There are one status LED connected to the system controller CPLD. When the FPGA is not configured the LED will flash continuously. Finally once FPGA configuration has completed the LEDs can be used in the user's FPGA design.

6.3 Dual channel USB to UART/FIFO

The TE0711-01 SoM has on-board high-speed USB 2.0 to UART/FIFO FT2232H controller from FTDI. Channel A can only be used in simple UART mode. Channel B can be used as UART in FT245 FIFO mode, JTAG (MPSSE) mode or in high-speed serial modes.

FT2232H controller is connected to the FPGA bank 14 with fixed 3.3V VCCIO and all signalling must meet the LVCMOS 3.3V I/O standard.

256 Byte EEPROM is connected to the FT2232H-chip to store custom configuration settings. These settings can be changed using FTDI provided tools that can be downloaded from [FTDI website](#)⁵.

⁴ <http://www.latticesemi.com/en/Products/DesignSoftwareAndIP/FPGAandLDS/LatticeDiamond.aspx>

⁵ <http://www.ftdichip.com/Products/ICs/FT2232H.htm>

7 Power and Power-On Sequence

7.1 Power Supply

Power supply with minimum current capability of 2A for system startup is recommended.

Power Input Pin	Voltage Range	Max Current
VIN	3.3V to 5.5V	Typical 200mA, depending on customer design and connections.
3.3VIN	3.3V	Typical 50mA, depending on customer design and connections.

Table 6: Typical power consumption.

✓ VIN and VIN3.3V can be connected to the same power source (3.3V).

Lowest power consumption is achieved when powering the module from single 3.3V supply. When using split 3.3V/5V supplies the power consumption (and heat dissipation) will rise, this is due to the DC/DC converter efficiency (it decreases when VIN/VOOUT ratio rises).

7.2 Power-On Sequence

For highest efficiency of on board DC-DC regulators, it is recommended to use same 3.3V power source for both VIN and 3.3VIN power rails. Although VIN and 3.3VIN can be powered up in any order, it is recommended to power them up simultaneously.

It is important that all baseboard I/O's are 3-stated at power-on until System Controller sets STAT_SC2 signal high (B2B connector JM1, pin 30), or 3.3V is present on B2B connector JM2 pins 10,12 or 91, meaning that all on-module voltages have become stable and module is properly powered up.

See Xilinx Artix-7 datasheet [DS181](#)⁶ for additional information. Also check related baseboard documentation when choosing baseboard design for TE0711-01 module.

A 3.3V supply is also needed and must be supplied from the user's PCB. An output 3.3V supply is available on some of the board connector pins (see section 'Power Rails'). The input 3.3VIN will be switched to the internal 3.3V voltage level after the FPGA 1.0V supply has stabilized. Than 3.3V supply will be available on the B2B connector pins.

The regulators can be powered from the 3.3V supply or a 5V supply if preferred. The options for powering the board are as follows:

- Apply 5V to pins VIN and 3.3V to pins 3.3VIN on the board connector
- Apply 3.3V to pins VIN and 3.3VIN on the board connectors.

⁶ https://www.xilinx.com/support/documentation/data_sheets/ds181_Artix_7_Data_Sheet.pdf

7.3 Power Rails

Voltages on B2B-Connectors	B2B JM1-Pin	B2B JM2-Pin	Direction	Note
VIN	1, 3, 5	2, 4, 6, 8	input	supply voltage
3.3VIN	13, 15	-	input	supply voltage
VCCIO15	9, 11	-	input	high range bank voltage
VCCIO34	-	1, 3	input	high range bank voltage
VCCIO35	-	7, 9	input	high range bank voltage
3.3V	-	10, 12	output	internal 3.3V voltage level
JTAG VREF	-	91	output	JTAG reference voltage (3.3V).
1.8V	39	-	output	internal 1.8V voltage level

Table 7: Power rails of SoM on B2B connectors.

7.4 Bank Voltages

Bank	Schematic Name	Voltage	Range
0 Config	3.3V	3.3V	-
14	3.3V	3.3V	-
15	VCCIO15	user	HR: 1.2V to 3.3V
16	1.8V	1.8V	-
34	VCCIO34	user	HR: 1.2V to 3.3V
35	VCCIO35	user	HR: 1.2V to 3.3V

Table 8: Range of FPGA's bank voltages.

See the Artix7 datasheet [DS181⁷](#) for the allowable voltage range.

⁷ https://www.xilinx.com/support/documentation/data_sheets/ds181_Artix_7_Data_Sheet.pdf

8 Board to Board Connectors

⚠ These connectors are hermaphroditic. Odd pin numbers on the module are connected to even pin numbers on the baseboard and vice versa.

4 x 5 modules use two or three [Samtec Razor Beam LSHM connectors](#)⁸ on the bottom side.

- 2 x REF-189016-02 (compatible to LSHM-150-04.0-L-DV-A-S-K-TR), (100 pins, "50" per row)
- 1 x REF-189017-02 (compatible to LSHM-130-04.0-L-DV-A-S-K-TR), (60 pins, "30" per row) (depending on module)

8.1 Connector Mating height

When using the same type on baseboard, the mating height is 8mm. Other mating heights are possible by using connectors with a different height

Order number	Connector on baseboard	compatible to	Mating height
23836	REF-189016-01	LSHM-150-02.5-L-DV-A-S-K-TR	6.5 mm
	LSHM-150-03.0-L-DV-A-S-K-TR	LSHM-150-03.0-L-DV-A-S-K-TR	7.0 mm
23838	REF-189016-02	LSHM-150-04.0-L-DV-A-S-K-TR	8.0 mm
	LSHM-150-06.0-L-DV-A-S-K-TR	LSHM-150-06.0-L-DV-A-S-K-TR	10.0mm
26125	REF-189017-01	LSHM-130-02.5-L-DV-A-S-K-TR	6.5 mm
	LSHM-130-03.0-L-DV-A-S-K-TR	LSHM-130-03.0-L-DV-A-S-K-TR	7.0 mm
24903	REF-189017-02	LSHM-130-04.0-L-DV-A-S-K-TR	8.0 mm
	LSHM-130-06.0-L-DV-A-S-K-TR	LSHM-130-06.0-L-DV-A-S-K-TR	10.0mm

Table 1: Connectors.

The module can be manufactured using other connectors upon request.

⁸ <https://www.samtec.com/technical-specifications/Default.aspx?SeriesMaster=LSHM>

8.2 Connector Speed Ratings

The LSHM connector speed rating depends on the stacking height; please see the following table:

Stacking height	Speed rating
12 mm, Single-Ended	7.5 GHz / 15 Gbps
12 mm, Differential	6.5 GHz / 13 Gbps
5 mm, Single-Ended	11.5 GHz / 23 Gbps
5 mm, Differential	7.0 GHz / 14 Gbps

Table 2: Speed rating.

8.3 Current Rating

Current rating of Samtec Razor Beam™ LSHM B2B connectors is 2.0A per pin (2 adjacent pins powered).

8.4 Connector Mechanical Ratings

- Shock: 100G, 6 ms Sine
- Vibration: 7.5G random, 2 hours per axis, 3 axes total

9 Variants Currently In Production

Module Variant	FPGA	FPGA Junction Temperature	Operating Temperature Range
TE0711-01-35-2I	XC7A35T-2CSG324I	-40°C to 100°C	Industrial grade
TE0711-01-100-2I	XC7A100T-2CSG324I	-40°C to 100°C	Industrial grade
TE0711-01-35-2C	XC7A35T-2CSG324C	0°C to 85°C	Commercial grade
TE0711-01-100-2C	XC7A100T-2CSG324C	0°C to 85°C	Commercial grade

Table 9: Differences between TE0711-01 module variants.

10 Technical Specifications

10.1 Absolute Maximum Ratings

Parameter	Min	Max	Units	Notes
VIN supply voltage	-0.3	7.0	V	EN6347QI, EN5311QI datasheet
3.3VIN supply voltage	-0.1	3.6	V	-
HR I/O banks supply voltage (VCCO)	-0.5	3.6	V	Xilinx datasheet DS181 ⁹
HR I/O banks input voltage	-0.4	VCCO + 0.55	V	Xilinx datasheet DS181 ¹⁰
Voltage on module JTAG pins	-0.5	VCCO_0 + 0.45	V	VCCO_0 is 3.3V nominal
Storage temperature	-55	+125	°C	-

Table 10: Absolute maximum ratings.

10.2 Recommended Operating Conditions

Parameter	Min	Max	Units	Notes
VIN supply voltage	2.4	5.5	V	EN5311QI data sheet
3.3VIN supply voltage	3.135	3.465	V	3,3V ± 5%
HR I/O banks supply voltage (VCCO)	1.14	3.465	V	Xilinx datasheet DS181 ¹¹
HR I/O banks input voltage	-0.20	VCCO + 0.2	V	Xilinx datasheet DS181 ¹²
Voltage on JTAG pins	3.135	3.465	V	3,3V ± 5%

⁹ https://www.xilinx.com/support/documentation/data_sheets/ds181_Artix_7_Data_Sheet.pdf

¹⁰ https://www.xilinx.com/support/documentation/data_sheets/ds181_Artix_7_Data_Sheet.pdf

¹¹ https://www.xilinx.com/support/documentation/data_sheets/ds181_Artix_7_Data_Sheet.pdf

¹² https://www.xilinx.com/support/documentation/data_sheets/ds181_Artix_7_Data_Sheet.pdf

Table 11: Recommended operating conditions.

10.3 Operating Temperature Ranges

Commercial grade: 0°C to +70°C.

Industrial grade: -40°C to +85°C.

Module operating temperature range depends also on customer design and cooling solution. Please contact us for options.

 Please check Xilinx datasheet ([DS181](#)¹³) for complete list of absolute maximum and recommended operating ratings.

10.4 Physical Dimensions

- Module size: 50 mm × 40 mm. Please download the assembly diagram for exact numbers.
- Mating height with standard connectors: 8mm
- PCB thickness: 1.6mm
- Highest part on PCB: approx. 2.5mm. Please download the step model for exact numbers.

All dimensions are shown in millimeters.

¹³ https://www.xilinx.com/support/documentation/data_sheets/ds181_Artix_7_Data_Sheet.pdf

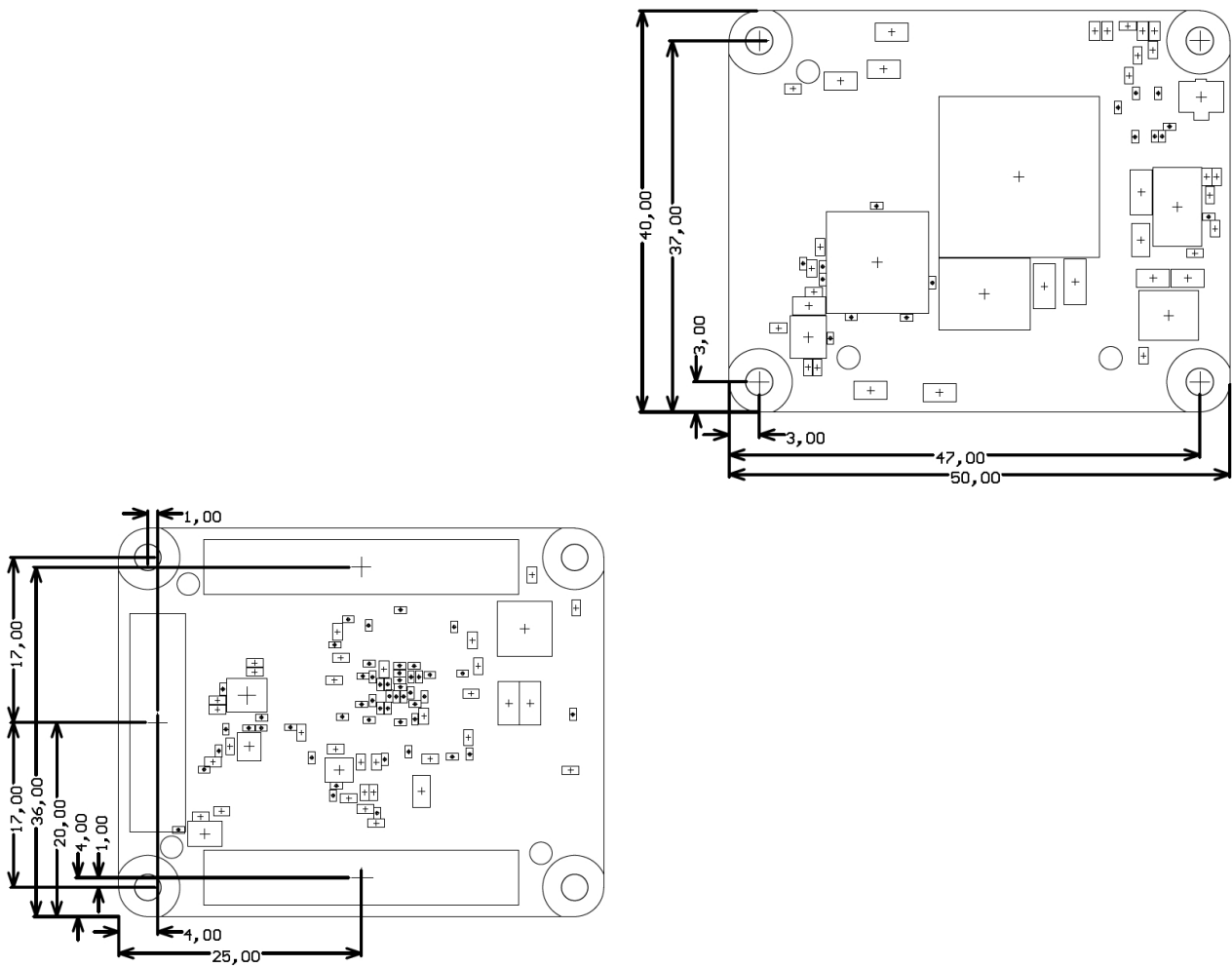

Figure 3: Physical dimensions of the TE0711-01 board.

10.5 Weight

20.6 g Plain module.

8.8 g Set of nuts and bolts.

11 Revision History

11.1 Hardware Revision History

Date	Revision	Notes	PCN	Documentation Link
2015-01-02	01	First production release		TE0711-01¹⁴

Table 12: Hardware revisions.

Hardware revision number is printed on the PCB board together with the module model number separated by the dash.



11.2 Document Change History

Date	Revision	Contributors	Description
 2018-04-20	v.35	John Hartfiel	<ul style="list-style-type: none"> Update Power Rail Section
2017-11-10	v.33	John Hartfiel	<ul style="list-style-type: none"> Replace B2B connector section
2017-01-29	v.30	Jan Kumann	<ul style="list-style-type: none"> New block diagram.
2017-01-01	v.10	Ali Naseri, Thorsten Trenz, Jan Kumann	<ul style="list-style-type: none"> TRM revision.
2015-06-05	v.1	Antti Lukats	<ul style="list-style-type: none"> Initial version.

¹⁴ https://shop.trenz-electronic.de/Download/?path=Trenz_Electronic/Modules_and_Module_Carriers/4x5/TE0711/REV01

12 Disclaimer

12.1 Data privacy

Please also note our data protection declaration at <https://www.trenz-electronic.de/en/Data-protection-Privacy>

12.2 Document Warranty

The material contained in this document is provided “as is” and is subject to being changed at any time without notice. Trenz Electronic does not warrant the accuracy and completeness of the materials in this document. Further, to the maximum extent permitted by applicable law, Trenz Electronic disclaims all warranties, either express or implied, with regard to this document and any information contained herein, including but not limited to the implied warranties of merchantability, fitness for a particular purpose or non infringement of intellectual property. Trenz Electronic shall not be liable for errors or for incidental or consequential damages in connection with the furnishing, use, or performance of this document or of any information contained herein.

12.3 Limitation of Liability

In no event will Trenz Electronic, its suppliers, or other third parties mentioned in this document be liable for any damages whatsoever (including, without limitation, those resulting from lost profits, lost data or business interruption) arising out of the use, inability to use, or the results of use of this document, any documents linked to this document, or the materials or information contained at any or all such documents. If your use of the materials or information from this document results in the need for servicing, repair or correction of equipment or data, you assume all costs thereof.

12.4 Copyright Notice

No part of this manual may be reproduced in any form or by any means (including electronic storage and retrieval or translation into a foreign language) without prior agreement and written consent from Trenz Electronic.

12.5 Technology Licenses

The hardware / firmware / software described in this document are furnished under a license and may be used / modified / copied only in accordance with the terms of such license.

12.6 Environmental Protection

To confront directly with the responsibility toward the environment, the global community and eventually also oneself. Such a resolution should be integral part not only of everybody's life. Also enterprises shall be conscious of their social responsibility and contribute to the preservation of our common living space. That is why Trenz Electronic invests in the protection of our Environment.

12.7 REACH, RoHS and WEEE

REACH

Trenz Electronic is a manufacturer and a distributor of electronic products. It is therefore a so called downstream user in the sense of REACH¹⁵. The products we supply to you are solely non-chemical products (goods). Moreover and under normal and reasonably foreseeable circumstances of application, the goods supplied to you shall not release any substance. For that, Trenz Electronic is obliged to neither register nor to provide safety data sheet. According to present knowledge and to best of our knowledge, no SVHC (Substances of Very High Concern) on the Candidate List¹⁶ are contained in our products. Furthermore, we will immediately and unsolicited inform our customers in compliance with REACH - Article 33 if any substance present in our goods (above a concentration of 0,1 % weight by weight) will be classified as SVHC by the European Chemicals Agency (ECHA)¹⁷.

RoHS

Trenz Electronic GmbH herewith declares that all its products are developed, manufactured and distributed RoHS compliant.

WEEE

Information for users within the European Union in accordance with Directive 2002/96/EC of the European Parliament and of the Council of 27 January 2003 on waste electrical and electronic equipment (WEEE).

Users of electrical and electronic equipment in private households are required not to dispose of waste electrical and electronic equipment as unsorted municipal waste and to collect such waste electrical and electronic equipment separately. By the 13 August 2005, Member States shall have ensured that systems are set up allowing final holders and distributors to return waste electrical and electronic equipment at least free of charge. Member States shall ensure the availability and accessibility of the necessary collection facilities. Separate collection is the precondition to ensure specific treatment and recycling of waste electrical and electronic equipment and is necessary to achieve the chosen level of protection of human health and the environment in the European Union. Consumers have to actively contribute to the success of such collection and the return of waste electrical and electronic equipment. Presence of hazardous substances in electrical and electronic equipment results in potential effects on the environment and human health. The symbol consisting of the crossed-out wheeled bin indicates separate collection for waste electrical and electronic equipment.

Trenz Electronic is registered under WEEE-Reg.-Nr. DE97922676.

 2018-09-18

¹⁵ <http://guidance.echa.europa.eu/>

¹⁶ <https://echa.europa.eu/candidate-list-table>

¹⁷ <http://www.echa.europa.eu/>